





F126

INTESTATRICE MANUALE ANGOLO VARIABILE MANUAL END-MILLING MACHINE WITH ADJUSTABLE ANGLE



Modello / Model	A	B	C	Kg
	1050	850	1600	130
	400v			
	1.1 kW			
	6 NI/min. 6,5 bar			

Intestatrice a singolo mandrino manuale orizzontale completa di carenatura zona lavoro. Completa di morse pneumatiche, dispositivo di fuori squadra -45° Dx o $+45^{\circ}$ Sx, cambio rapido del gruppo frese e refrigerazione pneumatica.

Manual/horizontal single-spindle end-milling machine complete with Integral guard of working area. Equipped with pneumatic clamps, out-of-square device -45° Right or $+45^{\circ}$ Left, pneumatic device for fast cutters changeover and pneumatic cooling system.

ACCESSORI IN DOTAZIONE:

- Cannotto portafrese $\varnothing 27 \times 160$
- Predisposizione evacuazione fumi e trucioli con bocca $\varnothing 95$
- Pistola aria con spirale m.4
- Manuale uso e manutenzione e catalogo ricambi
- Chiavi di servizio

STANDARD ACCESSORIES:

- Cutter sleeve $\varnothing 27 \times 160$
- Prearrangement for smokes and shavings suction/extraction units with mouth $\varnothing 95$
- Air-gun with 4 mts. hose
- User's and maintenance manual and spare parts catalogue
- Service keys

F126

INTESTATRICE MANUALE ANGOLO VARIABILE MANUAL END-MILLING MACHINE WITH ADJUSTABLE ANGLE

ANGOLO DI FRESATURA (con tutti i gradi intermedi)

WORKING SPAN (with all intermediate degrees)

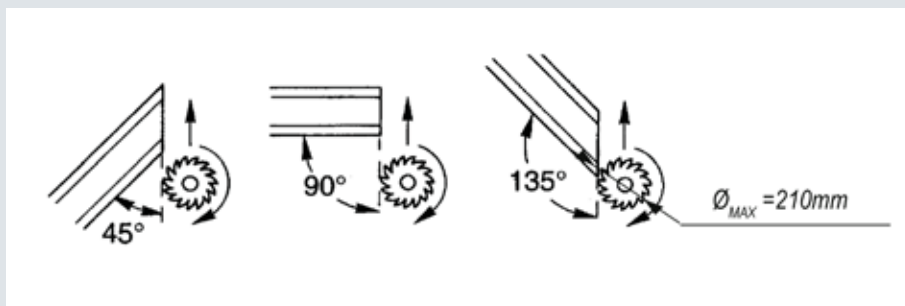

ACCESSORI A RICHIESTA

Codice / Code	Codice / Code	
001517672	Avanzamento manuale testa di fresatura Manual milling head feed	<input type="checkbox"/>
003517604	Avanzamento oleopneumatico testa di fresatura Oleo-pneumatic milling head feed	<input type="checkbox"/>
001517699	Coppia morse pneumatiche verticali Pair of vertical pneumatic clamps	<input checked="" type="checkbox"/>
002517612	Dispositivo pneum. sostituzione rapida gruppo frese Pneumatic device for fast cutter changeover	<input checked="" type="checkbox"/>
002517636	Fermo di battuta a 4 posizioni reg. Adjustable 4-positions end stop	<input checked="" type="checkbox"/>
001517633	Fermo profilo a 1 posizione Profile stop complete	ND
0N0517707	Refrigerazione pneumatica Pneumatic cooling system	<input checked="" type="checkbox"/>

OPTIONALS

I particolari evidenziati sono da specificare in sede di ordine.
By placing the order, please specify highlighted above parts.

ND = Non Disponibile / Not Available

= Optional a Richiesta / Optional on request

= Standard / Standard



GRAF SYNERGY S.r.l.

via galileo galilei n. 38 - 41015 nonantola (mo) italy

tel. +39 059 818256 - fax +39 059 8178161

info@grafsynergy.com - www.grafsynergy.com