





F131

FRESATRICE MANUALE MANUAL MILLING MACHINE



Fresatrice manuale con unità a forare orizzontale a 3 punte e unità a fresare verticale. Indispensabile per la lavorazione dei fori maniglia e scassi serratura su porte in PVC o alluminio già assemblate. Movimentazione unità di lavoro manuale tramite leve e dotata di morse pneumatiche orizzontali per blocco pezzo.

Manual milling machine with horizontal 3 spindle drilling unit and vertical milling unit. Specially designed for drilling handle-holes and lock-pickings on already assembled PVC and aluminium doors. Manual feed of drilling unit by means of levers and equipped with horizontal pneumatic clamps for blocking the workpiece.

| Modello / Model | A | B | C | Kg |
|---|-------------------|------|------|-----|
|  | 1200 | 1000 | 1600 | 100 |
|  | 400v | | | |
|  | 1.6 kW | | | |
|  | 5 NI/min. 6,5 bar | | | |

ACCESSORI IN DOTAZIONE:

- Coppia morse pneumatiche orizzontali
- N°2 aste laterali complete di n°2 fermi battuta
- N°1 fresa HSS monotagliente Ø 12mm – codolo Ø 8mm L=90
- N°2 punta HSS Dx: tagliente Ø 10mm - codolo Ø 8mm
- N°1 punta HSS Sx: tagliente Ø 12mm codolo Ø 8mm
- Pistola aria con spirale m.4
- Manuale uso e manutenzione e catalogo ricambi
- Chiavi di servizio

STANDARD ACCESSORIES:

- Pair of horizontal pneumatic clamps
- N° 2 lateral rods complete with n°2 profile stops
- N° 1 milling cutter HSS single cutting edge Ø 12mm –Ø 8mm shank L=90
- N° 2 milling bit HSS (Rh): Ø 10mm cutting edge –Ø 8mm shank
- N° 1 milling bit HSS (Lh): Ø 12mm cutting edge –Ø 8mm shank
- Air gun with 4 meter hose
- User's and maintenance manual and spare parts catalogue
- Service keys

F131

FRESATRICE MANUALE MANUAL MILLING MACHINE

CAPACITÀ DI FRESATURA

MILLING CAPACITY

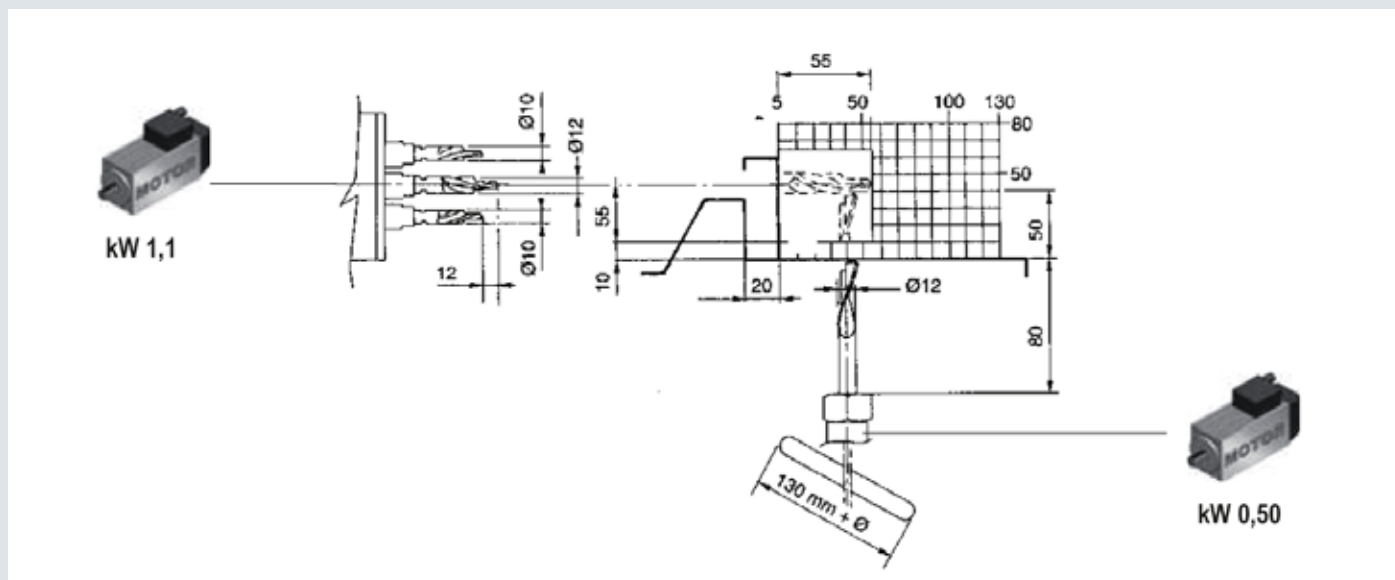

ACCESSORI A RICHIESTA OPTIONALS

| Codice / Code | Descrizione / Description |
|---------------|--|
| ON3517605 | Avanzamento oleopneumatico testa foratura Oleo-pneumatic drilling head feed |
| ON3517737 | Avanzamento manuale testa foratura Manual head movement |
| OM2517626 | Gruppo centratore profilo Profile centering device |
| ON5517632 | Fermo battuta con piastra 150x150 End stop with plate - 150x150 |
| ON5517711 | Sostegno profilo da 1500mm Sx+Dx Lh+Rh profile support - 1500mm |
| ON2517630 | Fermo stellare 4 posizioni 4-positions star shaped stop |
| ON0517634 | Fermo di battuta Profile stops |



GRAF SYNERGY S.r.l.
via galileo galilei n. 38 - 41015 nonantola (mo) italy
tel. +39 059 818256 - fax +39 059 8178161
info@grafsynergy.com - www.grafsynergy.com