

WP CNC 4

PULITRICE CNC A ASSI CONTROLLATI
CNC CORNER CLEANING MACHINE



6.5 kW



500 NI/min.
6,5 bar

PULITRICE AD ASSI CONTROLLATI

- 4 assi controllati, comandati da motori lineari
- Dimensione max. profilo 130Lx180H
- Lato minimo profilo 320 mm solo macchina (no tavolo)
- Centatura profili con riferimento sull'interno.
- Velocità max assi: 30 mt/min accelerazione max. teorica: 3÷4 m/sec²
- Ogni operazione può essere inserita o esclusa
- Avvio del ciclo automatico mediante la rilevazione dell'inserimento profilo
- Ciclo di lavoro gestito da PC
- Pannello di controllo con display TFT grafico a colori, tastiera di programmazione e selezione utensili
- Porta per chiave USB
- Creazione programmi tramite caricamento file DXF
- Acquisizione programmi tramite porta USB
- Gestione manuale di ogni organo meccanico
- Possibilità di utilizzare la macchina singolarmente o abbinata al tavolo per il caricamento automatico dei profili
- Regolazione automatica dei pressori a secondo dell'altezza del profilo
- Scorrimenti su assi temprati e rettificati e cuscinetti a sfera lineari.

CNC CORNER CLEANER MACHINE

- 4 CNC axis controlled by linear motors
- Profile max. dimensions: 130 L x 180 H
- Profile min. width 320mm processing with the machine (without turning station)
- Centering of profile with reference to the internal side
- Axis max. speed: 30mt./min theoretic max. acceleration: 3÷4 m/sec²
- Start-up of automatic operating cycle by placing the workpiece into the machine (by means of microswitches)
- Each operation can be separately selected or excluded
- Cleaning cycle managed by PC
- Control unit with graphic colour TFT display, with keyboard for programming and selecting tools
- USB port unit
- Programs learning by DXF profile file
- Data acquisition of any kind of system by USB port
- Manual handling of each mechanical member
- This machine has been designed to work separately or connected to the sash turning station DSI
- Automatic clamps setting according to profile height
- Axial and vertical movements on ball bearings and ground-hardened.

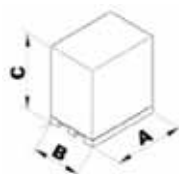

WP CNC 4				
Modello / Model	A	B	C	Kg
WP CNC 4	2300	1340	2350	1550
CONSOLLE / PALLET	1200	800	700	30

WP CNC 4

ACCESSORI IN DOTAZIONE:

- Gruppo filtro/riduttore lubrificatore per impianto pneumatico
- Coppia supporti appoggio profilo in lavorazione
- Pistola aria con spirale m.6
- Tanica olio da 1Lt per lubrificazione impianto pneumatico
- Manuale uso e manutenzione con lista parti di ricambio
- Chiavi di servizio

STANDARD ACCESSORIES:

- Filter/reducer lubricator unit for pneumatic system
- Pair of profile supporting arms
- Air gun with 6 mts. hose
- 1 Lt oil-can for lubricatio of pneum. system.
- User's and maintenance manual with spare parts catalogue
- Service keys

DIMENSIONI INGOMBRO GENERALI MACCHINA+TAVOLO / OVERALL DIMENSION WITH MACHINE AND TABLE

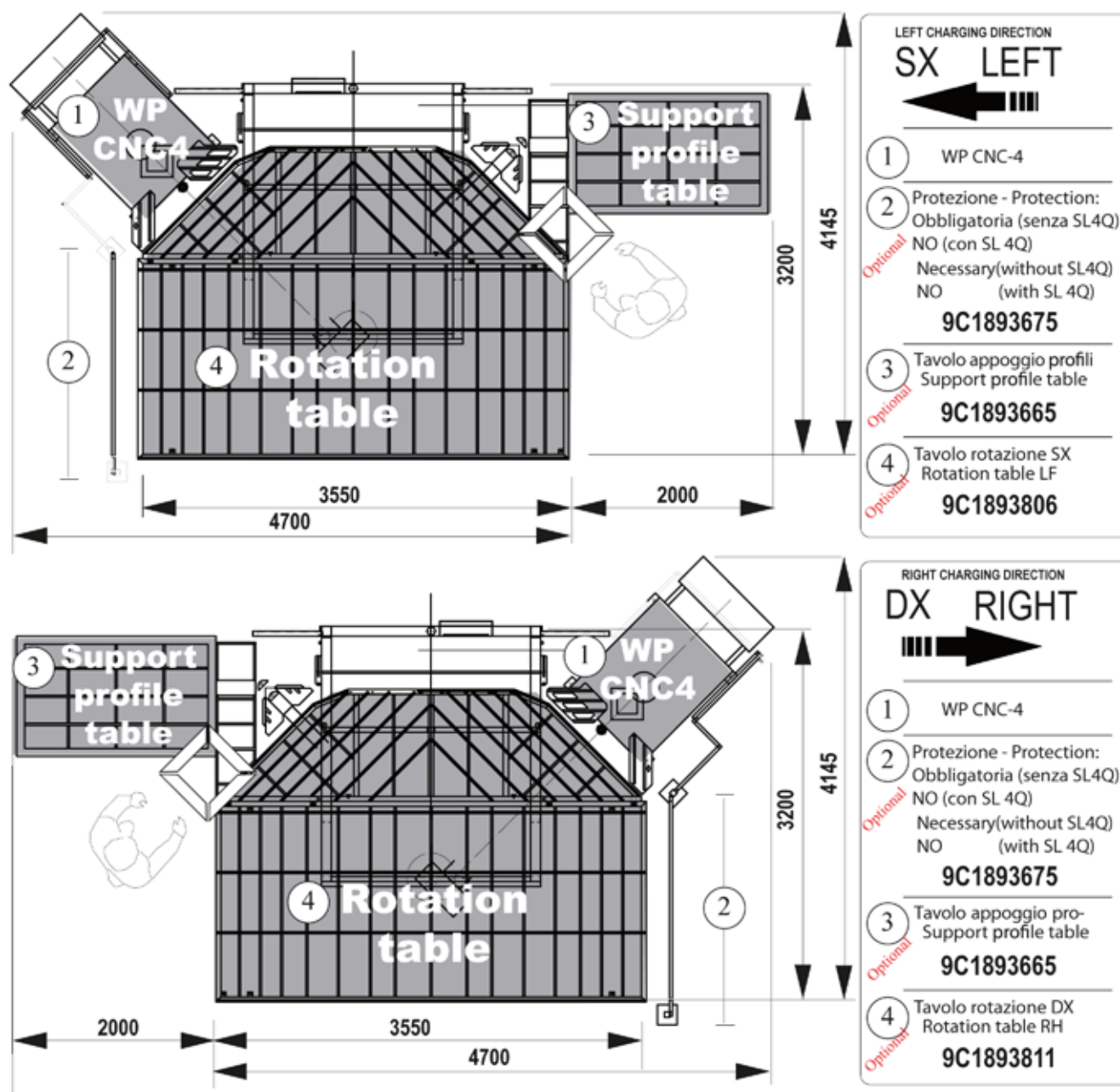

WP CNC 4

LAVORAZIONI ESEGUIBILI CON I DIVERSI ACCESSORI (DISPONIBILI A PARTE) /
MACHININGS FEASIBLE BY DIFFERENT ACCESSORIES (AVAILABLE SEPARATELY)

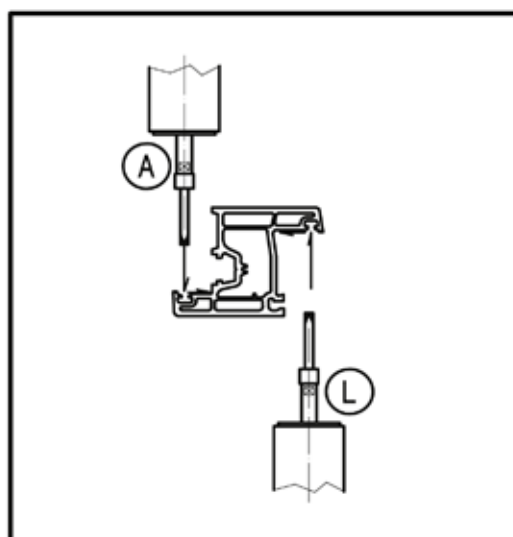
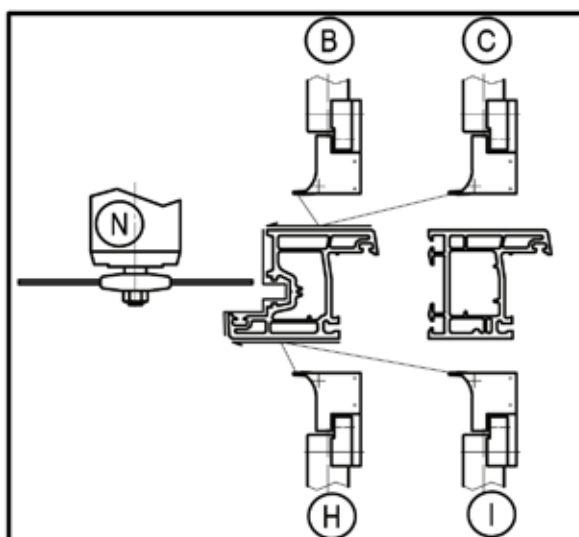
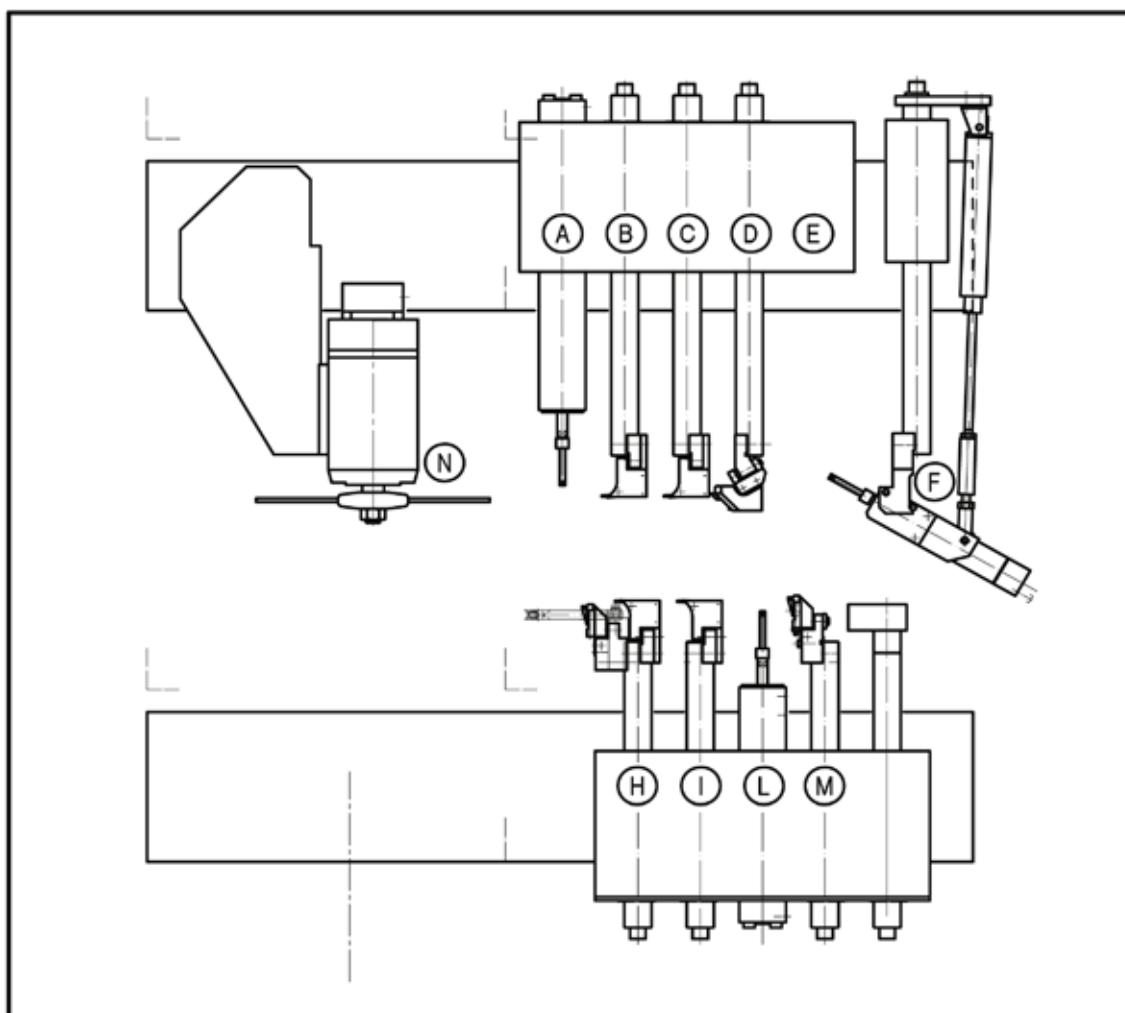

WP CNC 4

LAVORAZIONI ESEGUIBILI CON I DIVERSI ACCESSORI (DISPONIBILI A PARTE) /
MACHININGS FEASIBLE BY DIFFERENT ACCESSORIES (AVAILABLE SEPARATELY)

